

Bill Validator

A6/V6 Series Installation Guide

- 4 - Way Acceptance
- Low Maintenance
- Easy Installation
- Re - Programmable
Flash ROM
- Auto Self -Adjusting
Sensor System

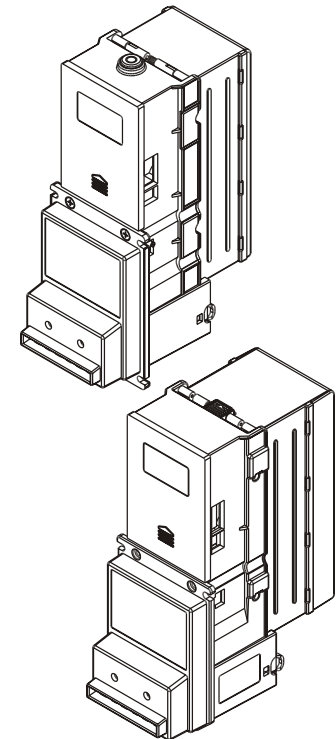

Part Number : H4458D
Version 5.0



International Currency Technologies
43010 Osgood Rd. Fremont, CA 94539
Tel : (510) 353-0289
Fax : (510) 353-0399
E-mail : sales@ict-america.com
Website : www.ict-america.com

Contents

A6 / V6 Bill Validator Specifications 2

LED Display 4

LED Status 4

A6 Pin-out Assignments (S.T.D Pulse for 12 V DC) 5

A6 Pin-out Assignments (S.T.D Pulse for 117 V AC) 6

A6 Pin-out Assignments (Multipuls for 117 V AC) 7

V6 Pin-out Assignments (M.D.B. System for 34V DC) 10

Cable 11

Switch Settings(Appendix)

A6/V6 Bill Validator Specifications

Acceptance Rate

96% or greater

Bill insertion

4-way Acceptance

Acceptance Speed

Approx. 3 seconds (including bill stacking)

Interfaces

S.T.D. Pulse
M.D.B. (Multi-Drop Bus)
Multipulse

Bill box Capacity

Approx. 300 bills (200~300)
500 bills (300~500)
800 bills (750~850)

◆ This guide contains all A6/V6 specs, but the actual machine matches only one of the specs.

Weight

Approx. 2kg (shipping)

Power Sources

34V DC 1.5Amp (M.D.B)
12V DC 3 Amp
117V AC 0.2Amp (60HZ)
24V AC 1.5Amp (60HZ)

Power Consumption

Max 50 watts

Environment Range

Operating Temperature $-15^{\circ}\text{C}\sim 60^{\circ}\text{C}$
Storage Temperature $-30^{\circ}\text{C}\sim 70^{\circ}\text{C}$
Humidity : 30%~85% RH (no condensation)

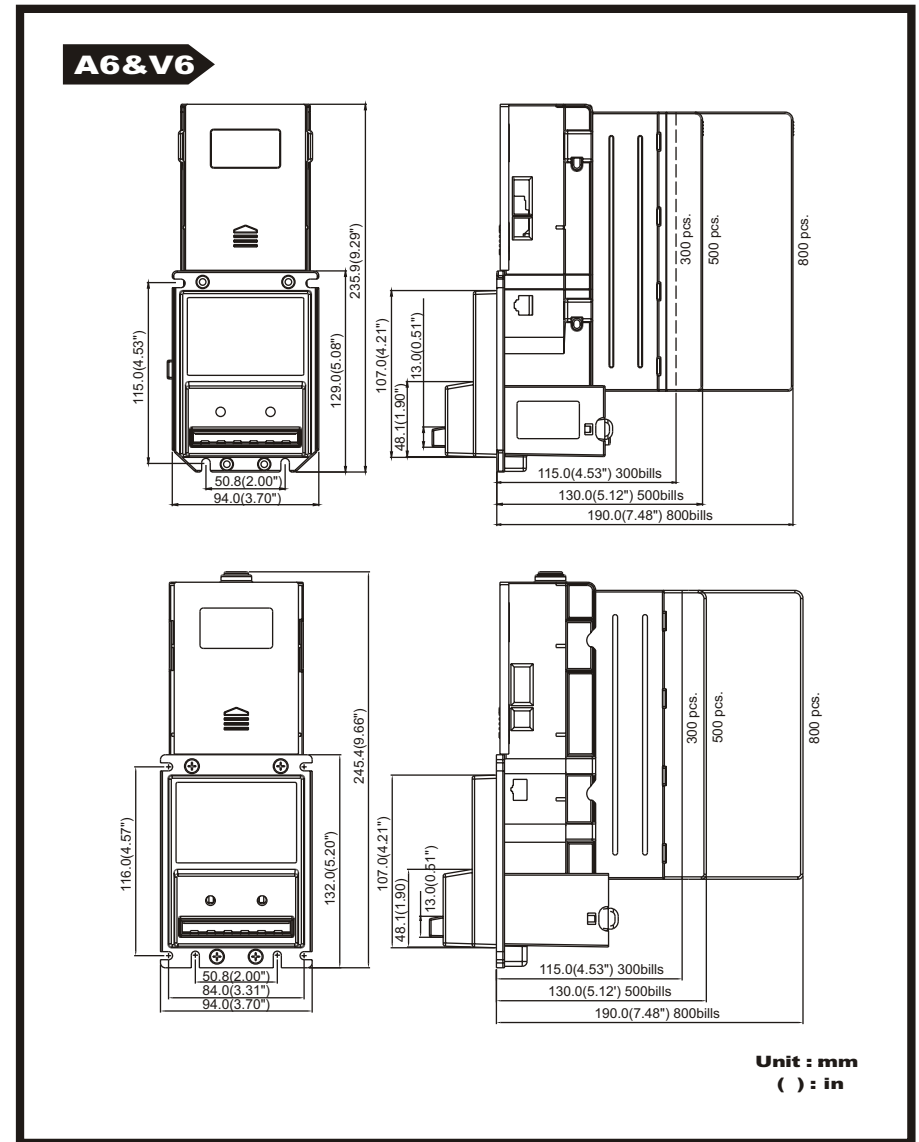

LED Display

The two LED lights located at the front of the unit will show the operational status of the bill validator. The LED lights will flash ON and OFF (in 500ms intervals) when the unit is ready to accept bills. The LED lights will be OFF if the unit is disabled or out of service, in which case the unit will not accept any bills.

The bill validator can only accept one bill at a time. The LED lights will be OFF and will not accept another bill while a bill is being validated in the unit. The LED lights will start to flash normally when the bill validator is ready to accept the next bill.

LED Status

DIAGNOSTICS LED ON =OK FLASHES	[GREEN LED] LED OFF =POWER OFF STATUS
1	bill jammed
2	disabled from system
3	sensor problem
4	reserved
5	bill box is removed
6	bill box is full of money

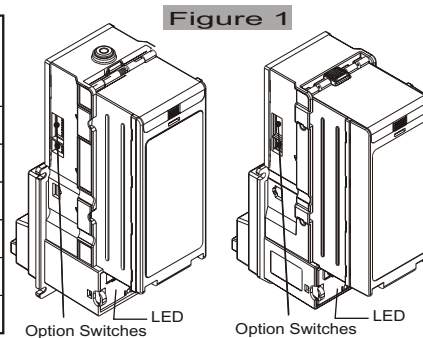

Note:

In addition to the 30-pin connector, there is also an 8-pin RJ-45 connector on the side of the bill validator designed for the purpose of downloading programs and updating validation software. The connector will be kept open under normal operation of the bill validator. It will only be used when new software or programs need to be downloaded into the flash ROM. The pin-out assignments of the 8-pin RJ-45 connector are as follows:

Pin 1 - GND	Pin 5 - /RESET
Pin 2 - TXD2	Pin 6 - VCC
Pin 3 - RXD2	Pin 7 - RXD1
Pin 4 - PROGRAM	Pin 8 - TXD1

A6 Pin-out Assignments (S.T.D. Pulse for 12V DC)

For the **12V DC** version of the A6 bill validator, the harness (*part no. WEL-M007*) has a dual-in-line 30-pin peripheral connector at one end and a 9-pin mating connector at the other end. Connect the 30-pin connector to the side of the bill validator and the 9-pin mating connector to the 12V DC power cable (part no. CU-961-1, see pg. 10 for pin-out info).

◆ 9-pin mating connector pin-out assignments:

Pin 1 INHIBIT +	Pin 6 Reserved
Pin 2 INHIBIT -	Pin 7 CREDIT + (N.O.)
Pin 3 Reserved	Pin 8 CREDIT - (Common)
Pin 4 Reserved	Pin 9 GND (Power)
Pin 5 12V DC (Power)	

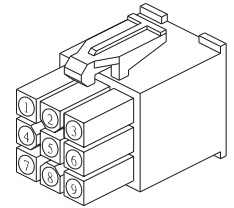

◆ Dual-in-line 30-pin peripheral connector (A6, 12V DC) pin-out assignments:

1	2	3	4	5	6	7	8	9	10	11	12	13	14	15
16	17	18	19	20	21	22	23	24	25	26	27	28	29	30

Pin 1 - CREDIT(-)(Common)	Pin 16 - CREDIT(+)(N.O.)
Pin 2 - 12VDC (Power)	Pin 17 - Reserved
Pin 3 - ENABLE(-)	Pin 18 - ENABLE (+)
Pin 4 - Reserved	Pin 19 - KEY
Pin 5 - INHIBIT (+)	Pin 20 - INHIBIT (-)
Pin 6 - KEY	Pin 21 - Reserved
Pin 7 - Reserved	Pin 22 - Reserved
Pin 8 - Reserved	Pin 23 - Reserved
Pin 9 - Reserved	Pin 24 - Reserved
Pin 10 - GND (Power)	Pin 25 - Reserved
Pin 11 - Reserved	Pin 26 - Reserved
Pin 12 - Reserved	Pin 27 - Reserved
Pin 13 - Reserved	Pin 28 - Reserved
Pin 14 - Reserved	Pin 29 - Reserved
Pin 15 - Reserved	Pin 30 - Reserved

◆ **CAUTION:** Turn off the power before connecting or disconnecting the bill validator.

A6 Pin-out Assignments (S.T.D Pulse for 117V AC)

For the 117V AC version of the A6 bill validator, connect the 30-pin peripheral connector on one end of the harness (part no. WEL-M008) to the side of the unit and the 9-pin mating connector to the 117V AC power cable (WEL-M012, see pg. 12 for pin-out info).

◆ 9-pin mating connector pin-out assignments:

- | | |
|-----------------------------|-----------------------------|
| Pin 1 NEUTRAL INHIBIT | Pin 6 117VAC NEUTRAL(Power) |
| Pin 2 NEUTRAL ENABLE | Pin 7 CREDIT RELAY (N.O.) |
| Pin 3 HOT ENABLE | Pin 8 CREDIT RELAY (Common) |
| Pin 4 117VAC HOT (Power) | Pin 9 Reserved |
| Pin 5 Earth - Ground | |

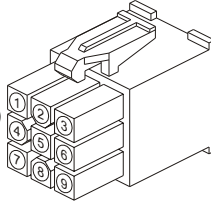

IMPORTANT: On 117V AC units, the Earth Ground must be located inside the machine.

◆ Dual-in-line 30-pin peripheral connector (A6, 117V AC) pin-out assignments:

1	2	3	4	5	6	7	8	9	10	11	12	13	14	15
16	17	18	19	20	21	22	23	24	25	26	27	28	29	30

- | | |
|-------------------------------|-----------------------------|
| Pin 1 - CREDIT_RELAY(COM) | Pin 16 - CREDIT RELAY(N.O.) |
| Pin 2 - Reserved | Pin 17 - Reserved |
| Pin 3 - NEUTRAL ENABLE | Pin 18 - HOT ENABLE |
| Pin 4 - 117VAC NEUTRAL(Power) | Pin 19 - KEY |
| Pin 5 - NEUTRAL INHIBIT | Pin 20 - 117VAC HOT(Power) |
| Pin 6 - KEY | Pin 21 - EARTH GROUND |
| Pin 7 - Reserved | Pin 22 - Reserved |
| Pin 8 - Reserved | Pin 23 - Reserved |
| Pin 9 - Reserved | Pin 24 - Reserved |
| Pin 10 - Reserved | Pin 25 - Reserved |
| Pin 11 - Reserved | Pin 26 - Reserved |
| Pin 12 - Reserved | Pin 27 - Reserved |
| Pin 13 - Reserved | Pin 28 - Reserved |
| Pin 14 - Reserved | Pin 29 - Reserved |
| Pin 15 - Reserved | Pin 30 - Reserved |

◆ **CAUTION:** Turn off the power before connecting or disconnecting the bill validator.

A6 Pin-out Assignments (Multipulse for 117V AC)

18 PIN Connector : Protocol Interface .

9 PIN Connector : Power for AC 117V + 5% .

◆ 9-pin mating connector pin-out assignments:

- | | |
|--------------------------|-----------------------------|
| Pin 1 Reserved | Pin 6 117VAC NEUTRAL(Power) |
| Pin 2 Reserved | Pin 7 CREDIT RELAY (N.O.) |
| Pin 3 Reserved | Pin 8 CREDIT RELAY (Common) |
| Pin 4 117VAC HOT (Power) | Pin 9 Reserved |
| Pin 5 Reserved | |

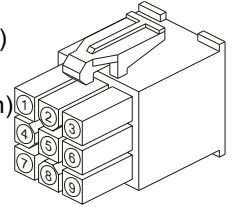

◆ Dual-in-line 30-pin peripheral connector (A6, 117V AC) pin-out assignments:

1	2	3	4	5	6	7	8	9	10	11	12	13	14	15
16	17	18	19	20	21	22	23	24	25	26	27	28	29	30

- | | |
|--------------------------------|-------------------------------|
| Pin 1 - CREDIT_RELAY_COM | Pin 16 - CREDIT RELAY (N.O.) |
| ★ Pin 2 - +12V | ★ Pin 17 - Reserved |
| ★ Pin 3 - NEUTRAL ENABLE | ★ Pin 18 - HOT ENABLE |
| Pin 4 - 117 VAC NEUTRAL(Power) | ★ Pin 19 - KEY |
| ★ Pin 5 - NEUTRAL INHIBIT | Pin 20 - 117 VAC HOT (Power) |
| ★ Pin 6 - KEY | ★ Pin 21 - EARTH GROUND |
| ★ Pin 7 - /\$1_CREDIT | Pin 22 - /OUT_OF_SERVICE |
| Pin 8 - /INTERRUPT | ★ Pin 23 - Reserved |
| ★ Pin 9 - /\$5_CREDIT | Pin 24 - /ACCEPT_ENABLE |
| Pin 10 - GND | ★ Pin 25 - /\$2_CREDIT |
| Pin 11 - /DATA | Pin 26 - /SEND |
| ★ Pin 12 - ESCROW_HIGH | ★ Pin 27 - \$1_ENABLE_LOW |
| ★ Pin 13 - \$5_ENABLE_HIGH | ★ Pin 28 - \$2_ENABLE_LOW |
| ★ Pin 14 - \$2_ENABLE_HIGH | ★ Pin 29 - \$5_ENABLE_LOW |
| ★ Pin 15 - \$1_ENABLE_HIGH | ★ Pin 30 - ESCROW_LOW |

⟨★⟩ **NOT USED.**

◆ **CAUTION:** Turn off the power before connecting or disconnecting the bill validator.

CONNECTOR

INTERFACE CONNECTOR :

◆ 18-pin mating connector pin-out assignments:

Pin 1 / \$ 1 CREDIT	Pin 10 /OUT-OF-SERVICE
Pin 2 INTERRUPT	Pin 11 /DEBUG DATA
Pin 3 / \$ 5 CREDIT	Pin 12 /ACCEPT ENABLE
Pin 4 GROUND	Pin 13 /\$ 2 CREDIT
Pin 5 /DATA	Pin 14 /SEND
Pin 6 ESCROW . High .	Pin 15 \$ 1 ENABLE , Low
Pin 7 \$ 5 ENABLE , High	Pin 16 \$ 2 ENABLE , Low
Pin 8 \$ 2 ENABLE , High	Pin 17 \$ 5 ENABLE , Low
Pin 9 \$ 1 ENABLE , High	Pin 18 ESCROW , Low

PIN LOCATIONS

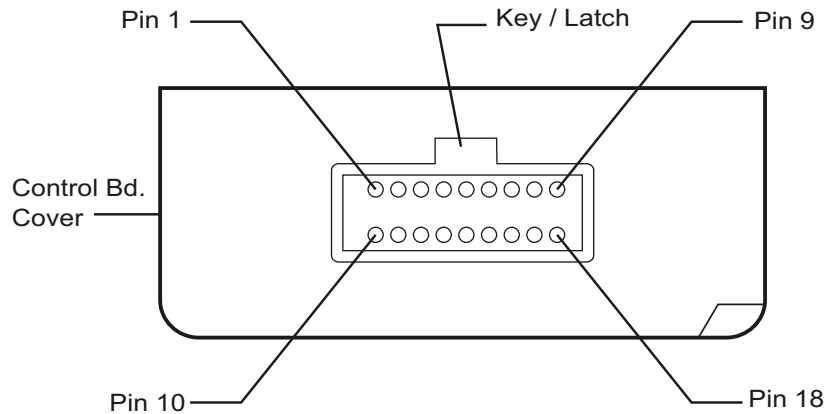

SERIAL INTERFACE

DATA TRANSMISSION TIMING

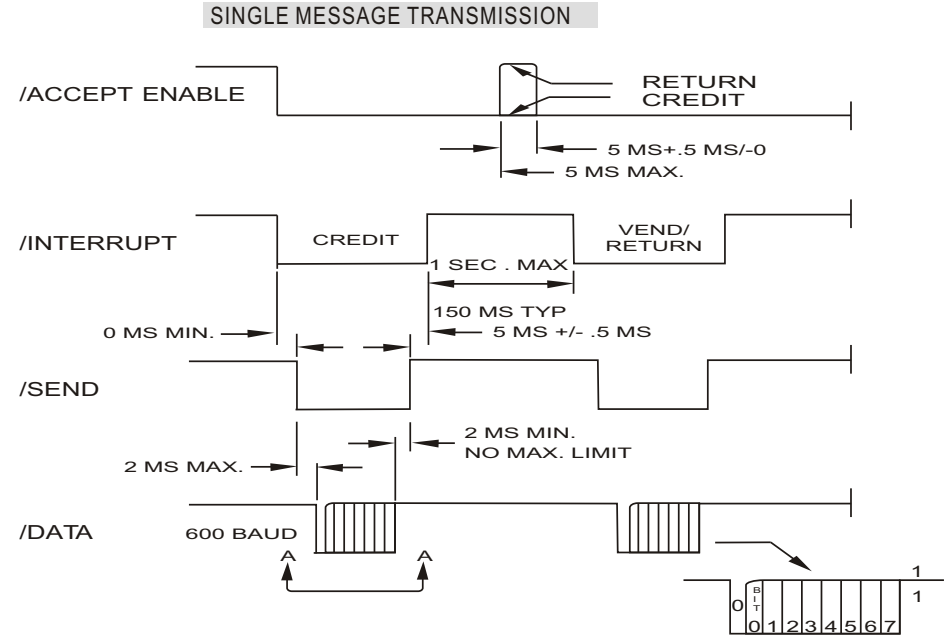

SERIAL INTERFACE STATUS MESSAGE

	MSB	7	6	5	4	3	2	1	0	LSB
		"1"	RESVRVD	CODES		STATUS	BILL	VALUE		HEX CODE
\$ 1 CREDIT	1	0	0	0	0	0	0	0	1	81
RESERVED	1	0	0	0	0	0	0	1	0	82
\$ 5 CREDIT	1	0	0	0	0	0	0	1	1	83
\$ 10 CREDIT	1	0	0	0	0	0	1	0	0	84
RESERVED	1	0	0	0	0	0	1	0	1	85
\$ 50 CREDIT	1	0	0	0	0	0	1	1	0	86
RESERVED	1	0	0	0	0	0	1	1	1	87
VEND	1	0	0	0	0	1	0	0	1	89
RESERVED	1	0	0	0	0	1	0	1	0	8A
SLUG	1	0	0	0	0	1	0	1	1	8B
FAILURE	1	0	0	0	0	1	1	0	0	8C
*1 STACKER FULL/ STACKERLESS JAM	1	0	0	0	0	1	1	0	1	8D

V6 Pin-out Assignments (M.D.B. System for 34V DC)

For the MDB interface V6 bill validator, connect the 30-pin peripheral connector on one end of the harness (**part no. WEL-M006**) to the side of the unit and the standard 6-pin MDB connector to the power/interface connector.

◆ The standard 6-pin MDB connector pin-out assignments:

- Pin 1 - 34 VDC
- Pin 2 - 34 VDC Power Return
- Pin 3 - N/C
- Pin 4 - Master Receive
- Pin 5 - Master Transmit
- Pin 6 - Communications Common

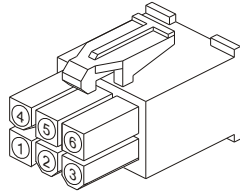

◆ Dual-in-line 30-pin peripheral connector (V6, MDB) pin-out assignments:

1	2	3	4	5	6	7	8	9	10	11	12	13	14	15
16	17	18	19	20	21	22	23	24	25	26	27	28	29	30

- | | |
|-------------------------|-----------------------|
| Pin 1 - Reserved | Pin 16 - 34VDC_RETURN |
| Pin 2 - Reserved. | Pin 17 - Reserved |
| Pin 3 - Reserved | Pin 18 - Reserved |
| Pin 4 - Reserved | Pin 19 - Reserved |
| Pin 5 - KEY | Pin 20 - GND |
| Pin 6 - MDB_MASTER_RXD | Pin 21 - KEY |
| Pin 7 - Reserved | Pin 22 - Reserved |
| Pin 8 - Reserved | Pin 23 - MDB +34VDC |
| Pin 9 - Reserved | Pin 24 - Reserved |
| Pin 10 - Reserved | Pin 25 - Reserved |
| Pin 11 - Reserved | Pin 26 - Reserved |
| Pin 12 - Reserved | Pin 27 - Reserved |
| Pin 13 - Reserved | Pin 28 - MDB_GND |
| Pin 14 - MDB_MASTER_TXD | Pin 29 - Reserved |
| Pin 15 - Reserved | Pin 30 - Reserved |

◆ **CAUTION:** Turn off the power before connecting or disconnecting the bill validator.

Cable

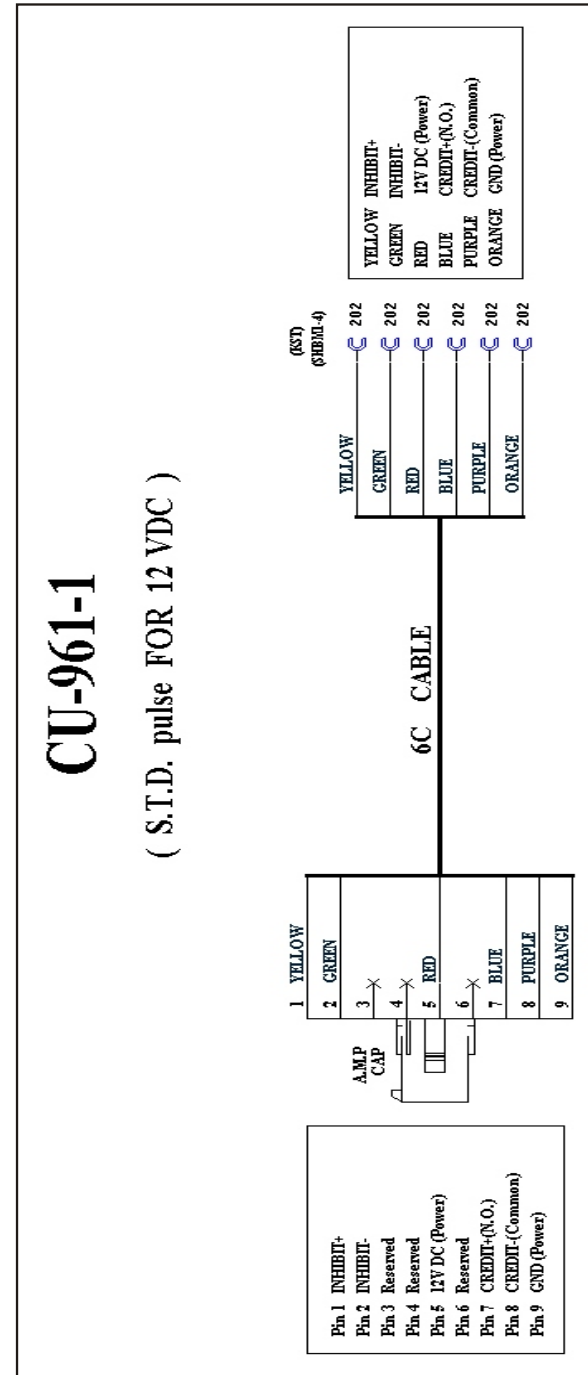

WEL-M010

(S.T.D pulse FOR 117 VAC)

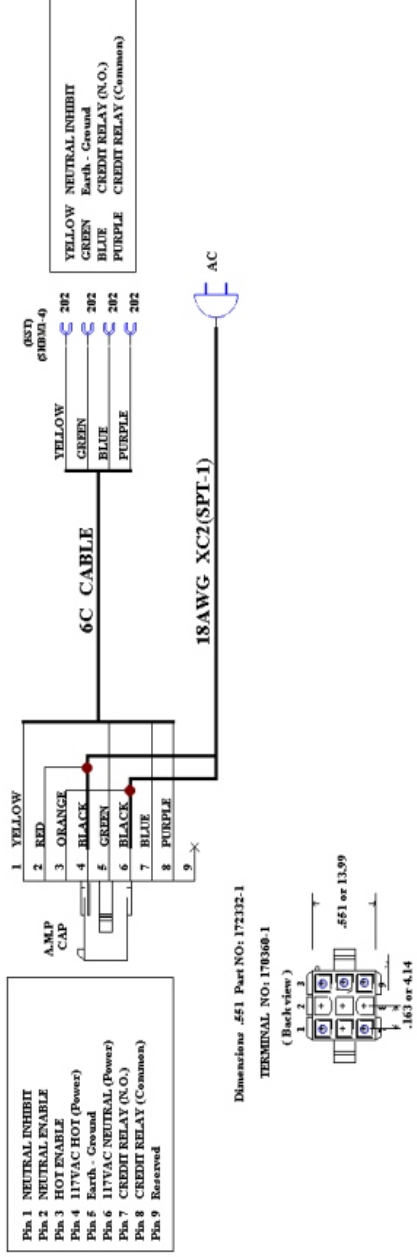

(Option)

WEL-M012

(S.T.D pulse FOR 117 VAC)

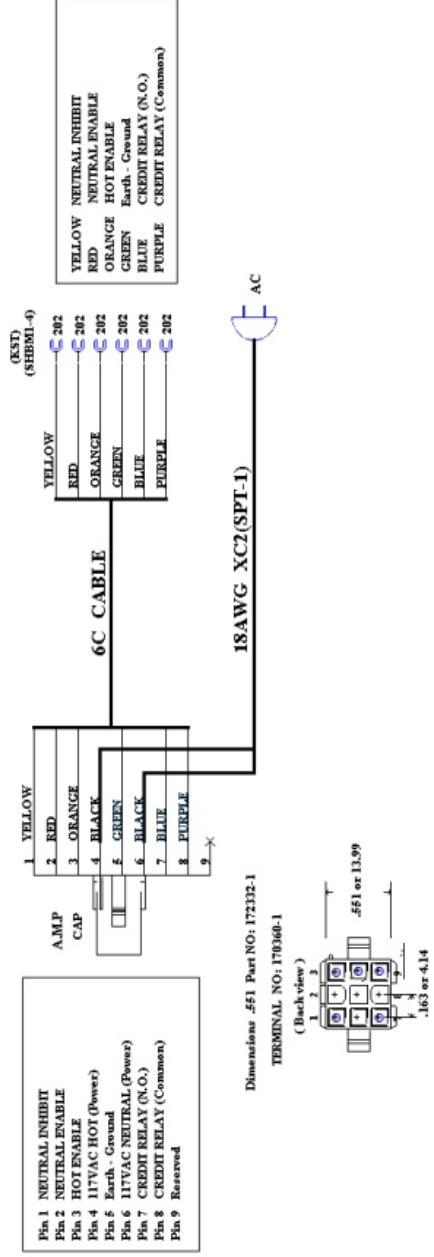

WEL-M013

(Multipulse FOR 117 VAC)

